

DISPLAY REFRIGERATOR

Model: 1RENGDHD

Natural Refrigerant R-290 Model

1-Section Extra-Wide Display Reach-In Refrigerator with Half Hinged Glass Doors



ENERGY STAR® Qualified Commercial Refrigerator

1RENGDHD - Stainless steel front, aluminum end panels and interior

1RENSAGDHD - Stainless steel exterior, aluminum interior

1RENSGDHD - Stainless steel exterior and interior



Options and Accessories

(upcharge and lead times may apply)

Stainless steel case back	Pan slide assemblies
Add'l epoxy-coated steel shelves	Wine rack
Chrome or stainless steel shelves	Adjustable legs
Heavy-duty pilaster strips	Pass-thru (consult factory)
Rehinging of doors (consult factory)	Special electrical req. (consult factory)

Consult factory for other model configurations, options and accessories.

Continental
Refrigerator

Toll-Free: 800-523-7138
Phone: 215-244-1400
Fax: 215-244-9579

539 Dunksferry Road
Bensalem, PA 19020
www.continentalrefrigerator.com

Project Name:

Model Specified:

Location:

Item No:

Quantity:

AIA #:

SIS #:

Standard Model Features

REFRIGERATION SYSTEM

Self contained, performance-rated refrigeration system

Natural, environmentally-safe, high-efficiency R-290 refrigerant¹

Automatic, electric condensate evaporator

Expansion valve system

CABINET ARCHITECTURE

3" non-CFC polyurethane foam insulation

Triple-pane, tempered hinged glass doors

Chrome-plated handles

Cam action, lift-off hinges

Self-closing doors

Magnetic snap-in door gaskets

Cylinder lock in each door

Heavy-duty, epoxy-coated steel shelves

5" casters

MODEL FEATURES

LED interior lighting

Electronic controller w/digital display & hi-low alarm

¹ R-290 refrigerant meets all federal and state regulatory requirements.

APPROVAL:

Model Specifications

DIMENSIONAL DATA

Net Capacity (cu. ft.)	21 (595 cu l)
Width, Overall (in.)	28 1/2 (724 mm)
Depth, Overall (in.) (incl. handles)	35 3/8 (899 mm)
Depth (in.) (less doors)	32 (813 mm)
Depth (in.) (doors open 90°)	58 (1473 mm)
Clear Door Width (in.)	21 7/8 (556 mm)
Clear Half Door Height (in.)	27 1/2 (699 mm)
Height, Overall (in.) (incl. 5" casters)	82 1/4 (2096 mm)
No. of Doors	2
No. of Shelves	4
Shelf Area (sq. ft.)	20.4 (1.9 sq m)
Tray Slide Capacity (per half section)	11

REFRIGERANT DATA

Condensing Unit Size (H.P.)	1/4+
Capacity (BTU/Hr)*	1940

ELECTRICAL DATA

Voltage (int'l)	115/60/1 (220/50/1)
Feed Wires (incl. ground)	3
Total Amps (int'l)	6.0 (4.2)
10 ft. Cord/Plug [attached] (int'l)	Yes (No)

SHIPPING DATA

Height - Crated (in.)	85 1/2 (2172 mm)
Width - Crated (in.)	31 5/8 (803 mm)
Depth - Crated (in.)	42 (1067 mm)
Volume - Crated (cu. ft.)	65 (1841 cu l)
Weight Std - Crated (lbs.)	335 (152 kg)
Weight SS - Crated (lbs.)	355 (161 kg)

* Rating @ +25°F evaporator, 90°F ambient

Figures in parentheses reflect metric equivalents rounded to the nearest whole unit.



Equipped with one NEMA-5-15P Plug
(varies by country)

Model Plan Views

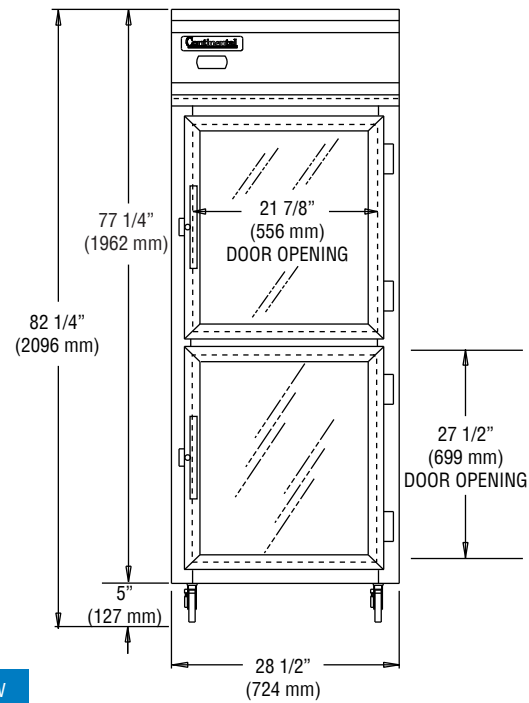

FRONT VIEW

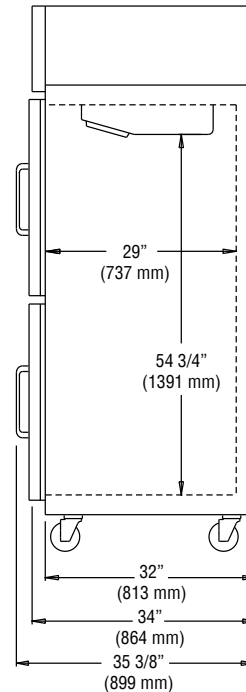

SIDE VIEW

IMPORTANT NOTE: If the cabinet is located directly against a wall and/or under a low ceiling, a minimum clearance of 12" is required on top and 3" on sides and rear.

Continental
Refrigerator

Toll-Free: 800-523-7138
Phone: 215-244-1400
Fax: 215-244-9579

539 Dunkserry Road
Bensalem, PA 19020
www.continentalrefrigerator.com

Due to our continued efforts in developing innovative products, specifications subject to change without notice.



Intertek



MADE IN THE U.S.A.

© Copyright 2019, Continental Refrigerator.
A Division of National Refrigeration & Air Conditioning Products, Inc.